

Microwave Sterilizer



선일플랜트 주식회사
Special Microwave High-technology Engineering

www.microwave-si.com

Table of Contents

- I 기업개요
- II 기술소개
- III 주요제품
- IV Microwave Medical Waste



선일플랜트
Special Microwave High-tech



I. 기업개요

Company Profile

I. 기업개요

선일플랜트(주) (Sunil plant co., ltd)

- 대표자: 이승훈
- 본사/공장 : 충청북도 청주시 흥덕구 강내면 저산태성로 165
- 웹 페이지 : <https://www.microwave-si.com>
- 창립일 : 2010년 3월

주요사업 (Main business)

MICROWAVE 기술 기반

- 산업용 건조 / 증발기
- 환경 정화 설비
- 자원 순환 설비
- 고온 반응로
- Microwave 부품
- 시스템 자동화
- 연구 개발 설비



I. 기업개요

주요 연혁 (Histories)



알루미나 허니컴 건조기
반도체 열처리 설비



195kW급 TiO₂ 건조기
배치 및 연속식 고온반응기



국가혁신클러스터(R&D) 수행
120kW급 고순도 알루미나 건조기
방사성탄소 C-14 재활용 설비



2024

380kW급 건조기
112kW급 예열기



2023

64kw 허니컴 건조기
배터리 음극재 반응기



2022

2021

64kW급 대형 허니컴 건조기
68kW급 MLCC 원료 건조기

2020

2011
~2019



2010

선일플랜트(주) 법인설립

II. 기술개요

Technology Profile

II. 기술소개

MICROWAVE 가열 (Microwave heating)

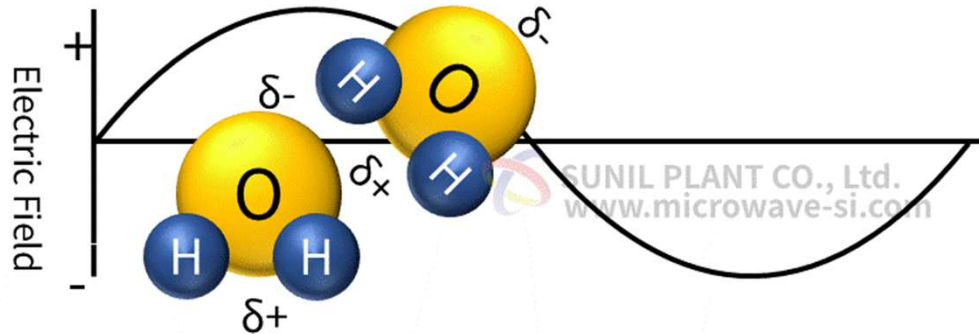

쌍극자 변화에 따라 24억 5천만번 극성변화(2.45GHz의 경우)로 발생하는 마찰열을 이용해 물질을 빠르고 균일하게 선택적 가열

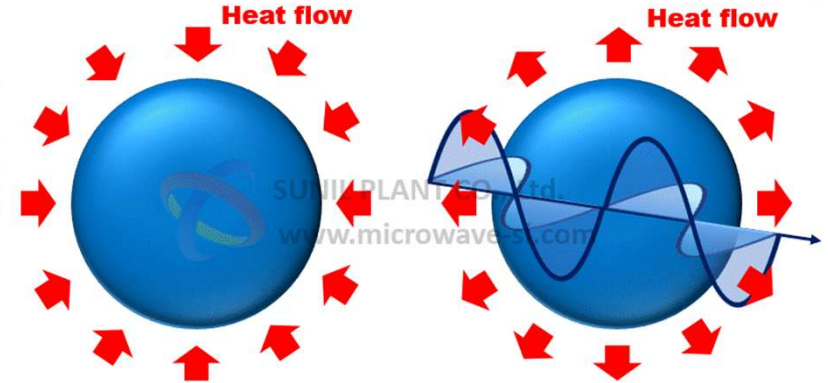

Conventional heating: Slow / High Loss 기존 가열
 Microwave heating: Direct Energy Transfer Microwave 가열

MICROWAVE 장점 (Microwave advantages)



에너지 절감
(Energy Savings)

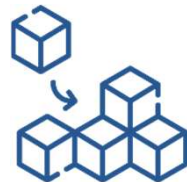

모듈형 설계
(Modular Design)



CO₂ 저감
(CO₂ Reduction)



살균 효과
(Sterilization)



운영 편의성
(Operational Convenience)



높은 효율
(High Efficiency)

II. 기술소개

MICROWAVE 기술 적용분야

“단일 기술을 넘어서 산업 전반에 적용되는 Microwave 솔루션”

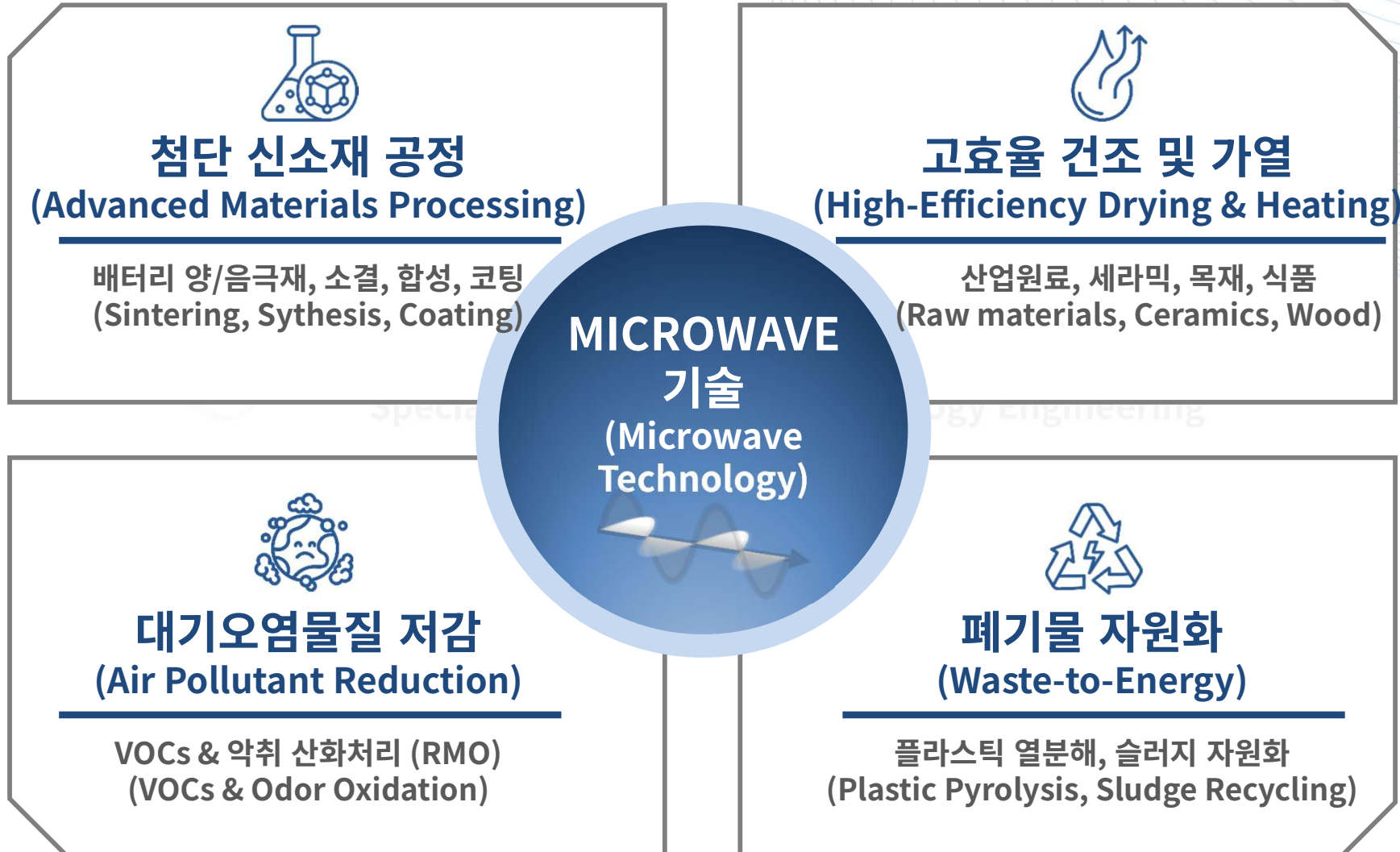

II. 기술소개

핵심 보유 기술 (Core Technologies)

“Microwave 설비, 공정 엔지니어링, 자동 제어까지 복합 솔루션 제공”

Microwave 시뮬레이션 기술 (Microwave simulation technology)

- Microwave 안테나 설계 기술
- 최적 효율의 mode 제어 기술
- Microwave 누설 차폐 기술

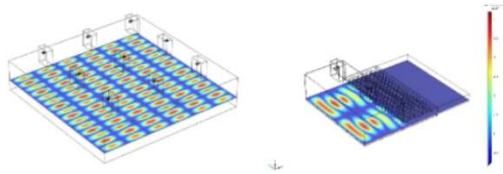

고온 발열 기술 (High-Temperature Heating)

- Microwave 발열체 기술
- 최적 발열 시스템 기술

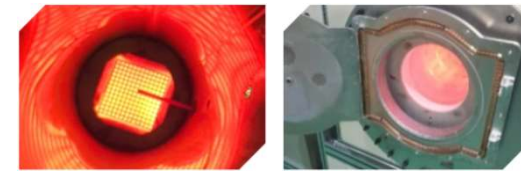

MICROWAVE 기술 (Microwave Technology)

모듈형 설계기술 (Modular design technology)

- Microwave 안테나 설계 기술
- 최적 효율의 mode 제어 기술
- Microwave 누설 차폐 기술

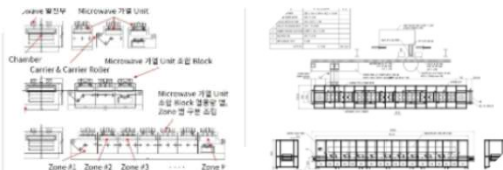

엔지니어링 / 자동제어 (Process Engineering / FA)

- 공정 최적화 엔지니어링 기술
- P&ID, PFD 등
- 공정에 맞는 자동제어 기술



III. 주요제품

Main Products

III. 주요제품

재생식 Microwave 산화기 (Regenerative Microwave Oxidizer, RMO)

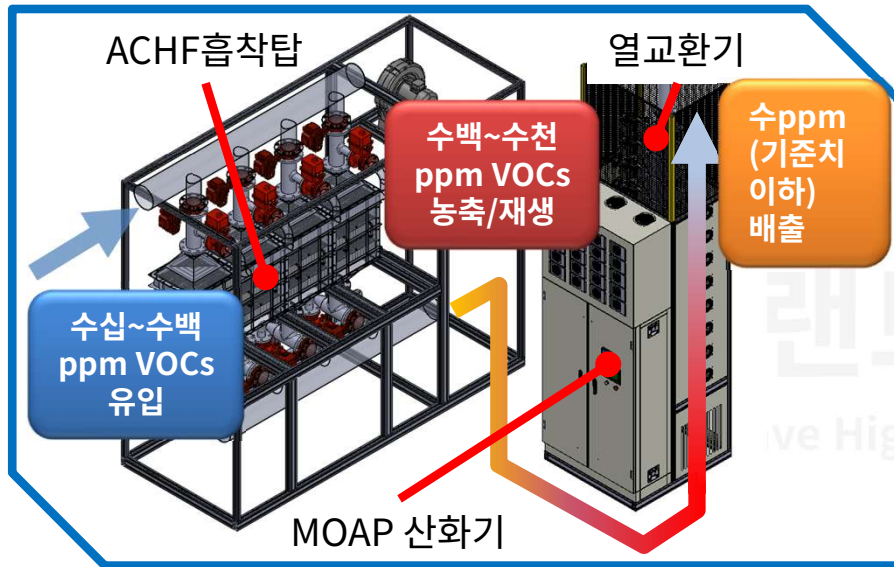
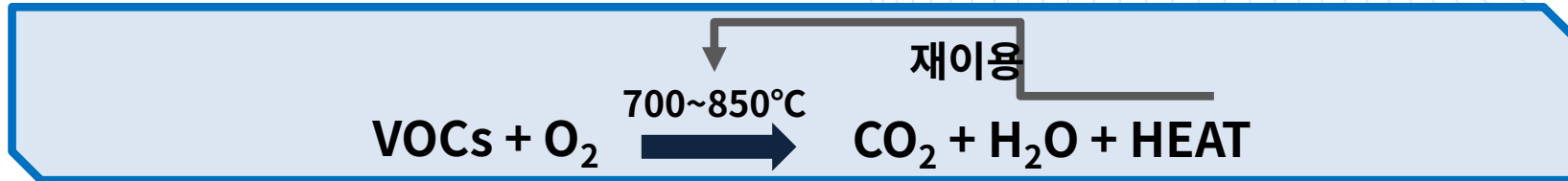

가스 종류	투입 가스 농도 (PPM)	처리 온도 (°C)	산화 처리 후 농도(PPM)
톨루엔	2000	650	400
	2000	900	무검출
	1000	600	80
	1000	850	1미만
벤젠	1000	600	80
	1000	800	무검출
	1000	850	2.5미만
	1000	900	무검출

AC 허니컴 흡착탑 (Activated carbon honeycomb filter)

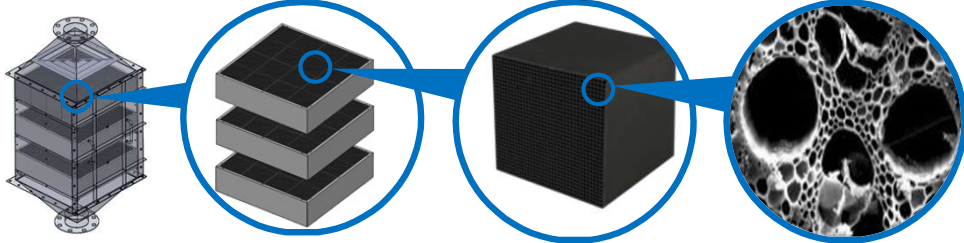

Microwave 산화기 (Microwave Oxidizer)

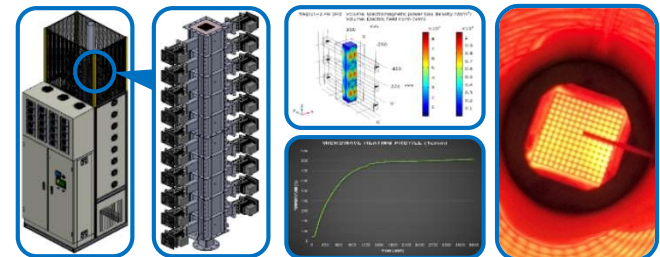

III. 주요제품

산업용 건조기 / 증발기 (Industrial microwave dryer / evaporator)



에너지 절감
(Energy Savings)

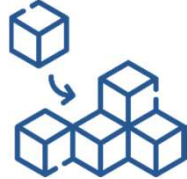

모듈형 설계
(Modular Design)



CO₂ 저감
(CO₂ Reduction)



살균 효과
(Sterilization)



운영 편의성
(Operational Convenience)



높은 효율
(High Efficiency)

“국내 유수의 기업으로부터 이미 검증된 산업용 건조기 제품”



380kW 세라믹분말 건조기



64kW Honeycomb 건조기



160kW Pouch 예열기



60kW 진공 목재건조기



120kW Alumina 건조기
선일플랜트 주식회사
Special Microwave High-technology Engineering



64kW Honeycomb 건조기



68kW MLCC 건조기



45kW Carbon 건조기

III. 주요제품

자원순환설비 (Waste Treatment Facilities)

“처리가 어려운 폐기물로부터 새로운 자원을 획득할 수 있는 친환경 설비”



중합체 열분해 장치



폐실리콘 자원화 설비



탄소핵종 회수 재활용 설비



폐활성탄 핵종제거 설비

고온 반응로 (High temperature furnace)

“저에너지 / 초고온으로 고속 승온 가능한 고온 반응로”



연속식 실리콘 음극재 반응로

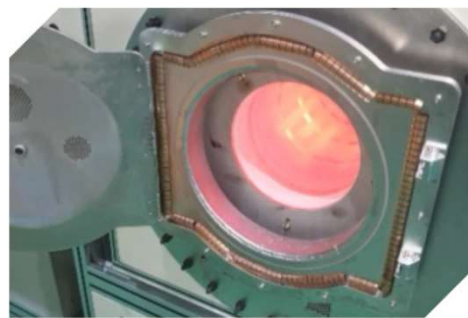

양극재 고온반응로



배기가스 정화장치



반도체 웨이퍼 고온 반응로



III. 주요제품

시스템 자동화 (Factory Automation)

“생산 공정에 맞춤 자동화 설비를 제어반, PLC, UI/UX, DATA 수집 통합공급”



자동 제어반 설계/제작

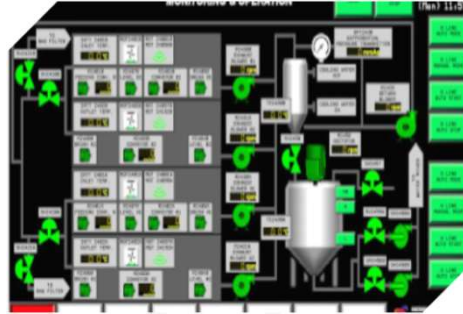

HMI 설계 / 제작

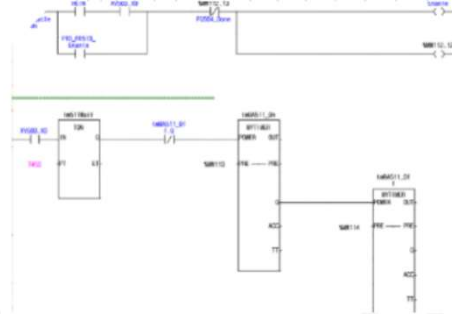

PLC logic 설계 / 제작



DATA 수집 및 기록

Microwave 부품 (Microwave components)

“다양한 Microwave 부품을 직접 생산 공급”



2kW Power-supply



1kW Power-supply



3kW Isolator

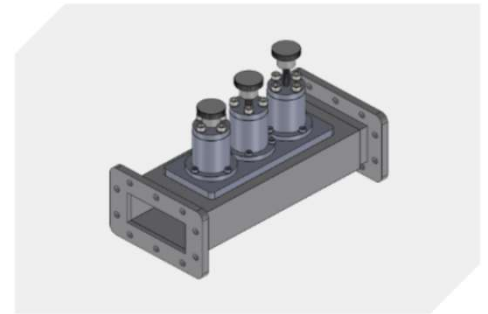

3-stub Tuner

IV. 의료 폐기물

Microwave Medical Waste Sterilizer

IV. 의료폐기물

의료폐기물의 정의 및 분류

보건·의료기관에서 배출되는 폐기물 중 인체에 감염 등 위해를 줄 우려가 있는 폐기물

의료폐기물

격리의료폐기물

- 감염병 예방
- 격리자 배출 폐기물



위해의료폐기물

- 조직물류
- 병리계
- 손상성
- 생물 화학
- 혈액오염



일반의료폐기물

- 탈지면, 붕대
- 일회용 기저귀
- 일회용 주사기
- 수액세트 등



전체 의료폐기물 중 약 85%가 Non-hazardous 폐기물에 해당



의료폐기물 파쇄/멸균 대상에 해당



World Health Organization

IV. 의료폐기물

의료폐기물 관리시장 (Medical Waste Management Market)

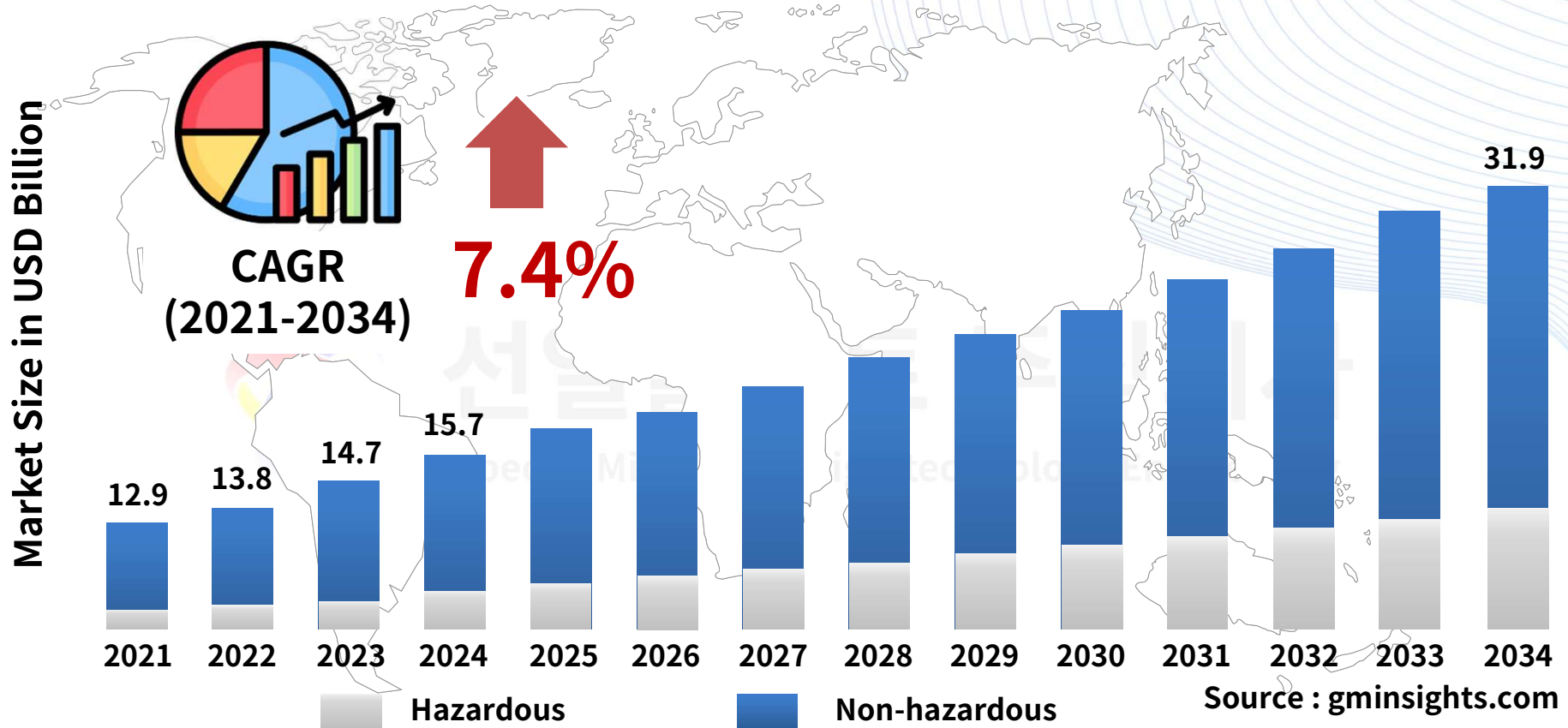

2021
12.9 USD billion (129억 달러)



2034
31.9 USD billion (319억 달러)

IV. 의료폐기물

의료폐기물 처리방법 변화

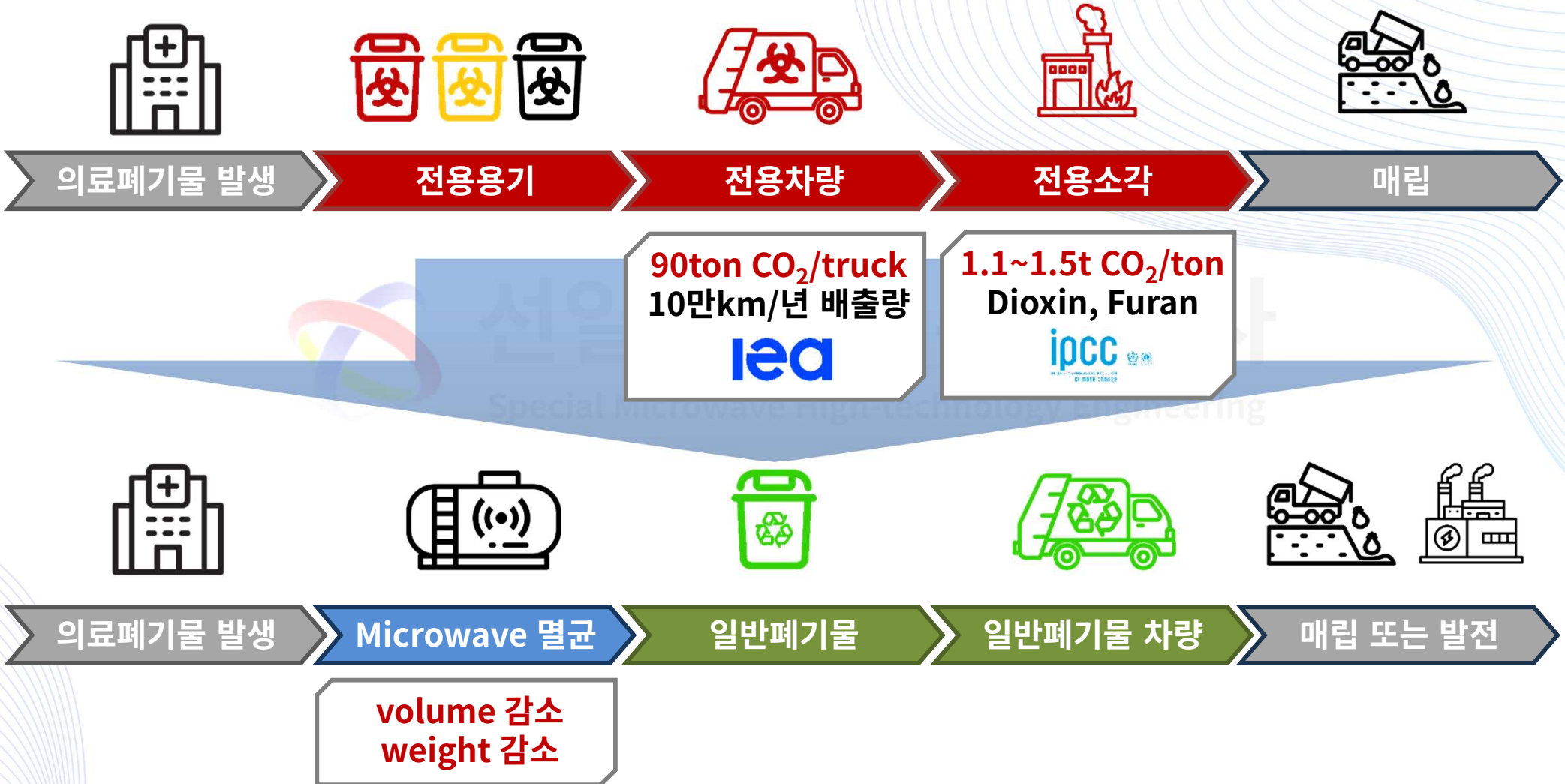

STAATT Level III (6-log₁₀) 이상 사멸 기준

IV. 의료폐기물

의료폐기물의 처리방법 비교

“위탁처리비용은 무게(Weight)를 기준으로 부과”

소각 (Incineration)



장점

- 90%이상 부피감소

단점

- 배출가스 문제
- 혐오시설/주민반대
- 처리비용 증가

오토클레이브 (Autoclave)



장점

- 기술적 신뢰도 높음
- 운영이 쉬움

단점

- 무게증가 (스팀흡수)
- 폐수 및 악취 발생
- 고온/고압으로 화재 위험

기존 마이크로웨이브 (Continuous Microwave)



장점

- 비소각 방식
- 연속처리 가능
- 무게감소 (20~30%)
- 부피감소 (80%)

단점

- 배기필터에만 의존
- 스크류 끼임 현상

마이크로웨이브



특징

- 비소각 방식
- 살균 / 건조 동시처리
- 순환으로 배기 최소화
- 무게감소 (~30%)
- 부피감소 (약 80%)

IV. 의료폐기물

의료폐기물의 처리방법 인증 및 규정

RA 8749(Clean Air Act)

대기배출 규제 (NCM, Sm³기준)

오염 물질	배출 허용량	분석 방법 및 비고
먼지 (Particulate Matter)	150 mg	표준 샘플링 기준
일산화탄소 (CO)	500 mg	연소 또는 열처리 효율 지표
질소산화물 (NOx)	1,000 mg	기존 소형 설비 기준
황산화물 (SOx)	500 ~ 1,500 mg	사용 연료 및 공정에 따라 차등
염화수소 (HCl)	10 mg	플라스틱(PVC 등) 가열 시 관리 대상
수은 (Mercury)	0.05 mg	의료기기 폐기물 처리 시 중요
다이옥신 및 퓨란	0.1 ng TEQ	국제 기준 (WHO/EU) 준용

DOH AO No.2007-0014, DOH Health Care Waste Management Manul(4th Edition, 2020)

STAATT Level III 기준

6-log₁₀ 사멸 확인

지표균: *Geobacillus stearothermophilus* 포자 사용

0.3 μm 이상 입자 99.97% 제거 (HEPA 필터)

IV. 의료폐기물

의료폐기물의 처리기

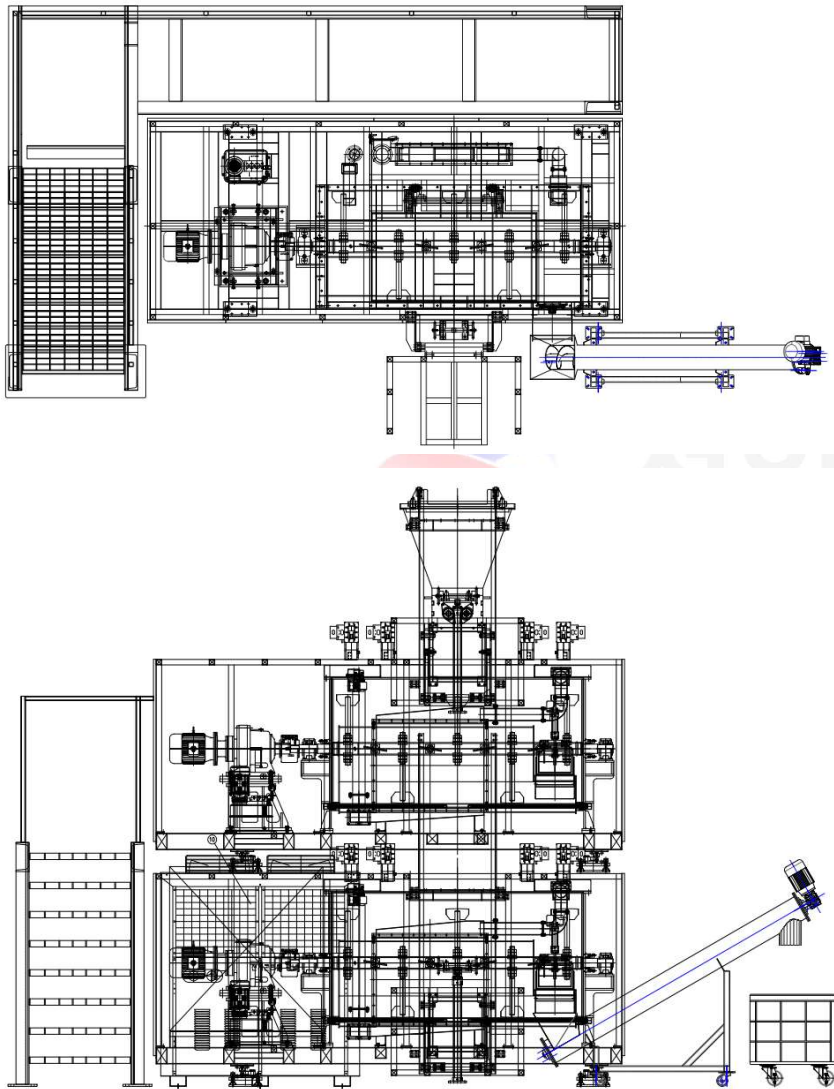

Microwave Sterilizer 300

Technical data

Throughput	300kg/hr (3,000 L/hr)
Dimensions (L x W x H)	11.4m x 5.7m x 5m
Type of process	Automatic and continuous process
Sterilizing temp.	95 ~ 110 °C (Temperature / Pressure control)
Process time	30 min ~ 1 hour / batch
Electrical power	80kWh (estimated)
Features	<ul style="list-style-type: none">- Auto lifting system- No material clogging on screw flight- Drying after sterilization process- Exhaust Gas Recirculation(EGR) for minimizing emission- Simultaneous Sterilization and Drying- Electrical only



IV. 의료폐기물

의료폐기물의 처리 전/후 비교

처리 전 의료폐기물



분쇄 멸균 처리 후



- STAATT Level III (6-log_{10}) 만족
- 20~30% 무게감소
- 80% 부피감소
- 형체 식별 불가능 (재사용 방지 목적)

IV. 의료폐기물

의료폐기물의 처리 기술 비교 (경제성)

Method	Capacity (kg/hr)	Capital cost (US\$ x 1000)	Operating cost (US\$/kg)
Autoclave	23 ~ 3,600	30 ~ 1,780	0.13 ~ 0.36
Chemical treatment	11 ~ 6,800	20 ~ 890	0.15 ~ 2.2
Microwave	23 ~ 410	70 ~ 710	0.10 ~ 0.42

Technology	Range of Capacities (kg/hr)	Range of Operating Costs (USD/kg)
Autoclave	2 ~ 3,600	0.14 ~ 0.33
Hybrid autoclave	18 ~ 2,200	0.05 ~ 0.12
Continuous steam treatment systems	100 ~ 1,800	about 0.15
Batch microwave unit	1.5 ~ 31	about 0.13
Continuous microwave unit	100 ~ 810	0.07 ~ 0.11
Frictional heating	10 ~ 1,500	0.07 ~ 0.11
Alkaline hydrolysis	7 ~ 4,500 kg/cycle	0.10 ~ 0.19
Chemical treatment	23 ~ 410	0.12 ~ 0.52

* Safe management of waste from health-care activities
- Second edition, WHO, 2014

* Compendium of Technologies for Treatment/Destruction of Health-care Waste, UNEP, 2012.



**WHO(세계보건기구)와 UNEP(유엔환경계획)이 인정한
마이크로웨이브 처리기술**



IV. 의료폐기물

마이크로웨이브 살균방식 경제성 (대한민국 500병상 기준)

구분	연간 발생량(Ton) / 비용(원)	비고
연간 의료폐기물 배출량	237 Ton	1)
멸균 분쇄가능 배출량	190 Ton	2)
시간당 요구처리량	65 kg	3)
적정 처리용량	100kg/hr	4)
의료폐기물 위탁처리단가	1,000,000원/Ton	5)
사업장 예상 연간 배출량	142 Ton	6)
일반폐기물 위탁처리단가	250,000원/Ton	7)
연간 추정 이익	142,500,000원	8)

ROI

(Return on Investment)

3년 이내

- 1) 평균 1.3kg/병상 (병상 가동률 85~90% 기준) x 500병상 x 365일 (출처 : 국회입법조사처, 한국환경공단)
- 2) 연간 의료폐기물 발생량 x 멸균분쇄 가능 폐기물 비중 (80%)
- 3) 멸균 분쇄가능 배출량 ÷ 365일 ÷ 8시간
- 4) 시간당 요구처리량 x 설비여유율 (50%)
- 5) 2024년 의료기관 ESG 경영사례집(건강보험심사평가원), 한국의료폐기물 공제조합
- 6) 멸균 분쇄가능 배출량 x 75% (25% 감량 기준)
- 7) 조달청 나라장터, 국립수산과학원 공고 제2023-365호
- 8) (의료폐기물 위탁처리단가 - 일반폐기물 위탁처리단가) x 190 ton

“10년 이상의 전문성, 기술을 현실로 만드는 기업”

“귀사의 혁신, 선일플랜트와 함께 시작하십시오”



주소 : 충북 청주시 흥덕구 강내면 저산태성로 165



Homepage : <https://microwave-si.com>



E-mail : sunil@microwave-si.com



전화 : 043 - 236 -3054

Fax : 043 - 236 -3024



선일플랜트 주식회사
Special Microwave High-technology Engineering